

This article describes a Buck and Boost Grid-Connected PV Inverter that maximizes power output from two PV arrays under unfavorable climatic circumstances.

¹Dr. K.Suneeta Professor, ²Mr. N.Laxman Assistant Professor

³Mr. B.Sreenu Assistant Professor
Department of EEE Engineering,

Nagole Institute of Technology and Science

Abstract:

For maximum power extraction from two serially linked subarrays, a single phase grid-connected transformerless photovoltaic (PV) inverter, which may work in either buck or boost mode and can extract the maximum power concurrently from both subarrays, is presented in this study. When employing an inverter that can function in buck or boost mode depending on the application, it is much less limiting to use a minimum number of serially linked solar PV modules to construct a subarray. Because of this, when each subarray is exposed to a new set of environmental factors, the power yield from each subarray grows. For the leakage current associated with PV arrays to stay within a given range of values, the topological configuration of the inverter and its control technique must be such that high-frequency components are not present in the common mode voltage. On top of that, a high level of productivity is maintained during the whole working range. In order to determine whether or not a project is feasible, a detailed study of the system is carried out, leading to the creation of a mathematical model of the system. A 1.5 kW laboratory prototype is needed to show the design's correctness via extensive testing..

Index Terms—Buck and Boost based photovoltaic (PV) inverter, grid connection, maximum power point (MPP), mismatched environmental condition, series connected module, single phase, transformer less.

INTRODUCTION

For solar-electric (PV) array design, one of the most critical issues is making sure that individual PV modules function at their optimum capacity even when exposed to varying external circumstances because of variances in insulation level and/or operating temperature. The output of a solar-electric array is significantly reduced when the operational parameters of the modules are incompatible. Solving the issue of MECs (mismatched environmental conditions) gets more difficult as the number of PV modules in a solar PV array increases. To meet the voltage requirements of an inverter in a grid-connected transformer-less (GCT) PV system, a high number of series-linked modules are necessary. A GCT PV system requires a certain number of series-linked modules, as shown in Figure 1. The MEC substantially reduces the power output of a GCT PV system, such as a single phase GCT (SPGCT) inverter based system produced from H-bridges or a neutral point clamp (NPC) inverter based system. As a result of the MEC in a PV system, a variety of solutions have been proposed in the literature. Each of these strategies is thoroughly examined in this paper, which provides a detailed description.

Tracking a PV array's global maximum power point (MPP) using MPPT, a complex algorithm, may maximise the amount of energy harvested during MEC by locating the array's MPP. It is possible to maximise the quantity of power harvested during MEC by choosing the right connection between PV modules or by monitoring the global maximum power point (MPP) of the PV array. In the case of low-power SPGCT PV systems, these techniques are ineffective. For SPGCT solar systems, altering the electrical connections of solar panels to reconfigure them as an array is unsuccessful because of the significant increase in components and escalation in complexity. PV modules in an array have been individually regulated, either via the use of a power electronic equalisation system or by connecting a direct current to direct current converter, in order to capture the maximum power possible from each PV module during MEC. There are many components required for systems that employ a power electronic equaliser, which adds to the expense and complexity of operation. PV modules are all operated at their maximum power point (MPP), and the generation control circuit (GCC) of the system manages the difference in power across modules. Each module in an array may be compensated for its shunt current and series voltage, as stated in the system. This will increase the array's power yield. Specialized DC-DC converters incorporated into each PV module are used in PV system integration solutions. Due to the huge number of converter stages and components used in the above systems, their efficiency is low, and as a consequence, they have the same constraints as the power electronic equalizer-based system described above. By connecting together a number of modules sequentially to make a string, it is feasible to generate a string that may be used under MPP in the same way as each individual module. Even in this case, the total number of parts and the level of complexity of the control system are only somewhat reduced.

Two subarrays of PV modules have been reported in literature, each having a different maximum power point for operation (MPP).

As a result, the control setup is simplified, and the system's component count is kept to a minimum. It has been proved that both strategies are ineffective in terms of total efficiency. MEC phase of the solar PV system is optimised by the SPGCT PV inverter's inverter's buck and boost stages. When an intermediate boost stage was developed, it allowed for a reduction in the number of series-connected PV modules and solar panels required in a PV array. There is a considerable decrease in the number of passive elements in both the dc to dc converter stage and the inverter stage of the schemes discussed here, which results in a gain of operational efficiency. According to, the advertised efficiency of is one to two percentage points greater than the actual efficiency of of There has been a determined effort in this study to partition the PV modules into two serially linked subarrays, and each subarray is controlled by buck and boost based inverters. There are half as many series-connected modules in this subarray using this way of dividing an input PV array into two subarrays, compared to the methods described in (see Figure 1). Inverters may be able to keep solar array leakage current to tolerable levels using topological structures and control methods similar to those presented here.

Due to the lower voltage stress across the active devices, the switching loss may operate at very high frequencies without rising as mentioned in. As a result of using high-frequency operation, passive components may be reduced in size, which is an advantage. As a consequence, the suggested technique is very operationally effective. The recorded peak efficiency and European efficiency (measured in euros) were both 97.65 percent and 97.02 percent, respectively, when the suggested strategy was utilised. The proposed inverter's functioning is described in detail here, along with mathematical proof that it works as expected. It then moves on to build a mathematical model of the suggested inverter, which will be followed by a philosophical approach to control strategy in Section IV. Section V moves on to the subject of filter component values after covering the selection criterion for the values of the output filter components, which also includes the values of the input filter components. According to Section VI of this study, extensive simulation studies have been done to verify the suggested strategy, and the results of these studies are reported. Prototypes of the proposed 1.5 kW inverter have been built in order to conduct extensive testing on the device under consideration. Results of the scheme's measures are shown in Section VII, which establishes its feasibility and effectiveness while also establishing its feasibility and effectiveness, respectively..

PROPOSED INVERTER

A dc to dc converter step is followed by an inverting stage, as seen in the schematic, to form the dual-buck and boost-based inverter (DBBI) suggested in this paper (see Fig. 1). A total of two dc to dc converter segments, CONV1 and CONV2, are used to service the two subarrays of the solar PV array, PV1 and PV2, respectively. The dc to dc converter stage is separated into two separate dc to dc converter segments, CONV1 and CONV2. Among the components of the CONV1 section are the following:

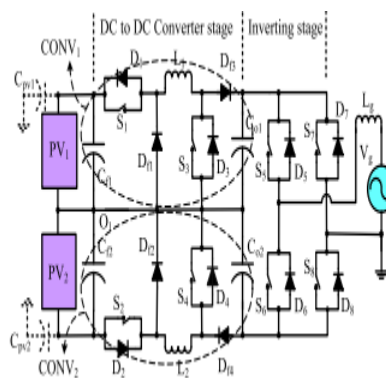

Fig. 4.1. Dual buck and boost based Inverter.

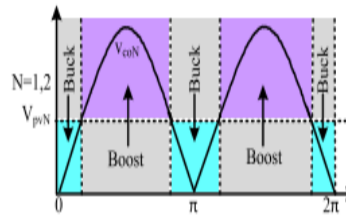

Fig 4. 2. Buck stage and boost stage of the proposed inverter.

In addition to the free-wheeling diodes Df 1 and Df 3, the circuit includes self-commutating filters, inductors, and capacitors L1, Cf 1, and Co1, as well as self-commutating diodes Df 1 and Df 3. Furthermore, self-commutated switches S1 and its antiparallel body diode D1 are self-commutated switches, as is S3 and its antiparallel body diode D3, in addition to being self-commutated switches. The self-commutated switches S2 and S4 as well as their antiparallel body diodes D2 and D4, the free wheeling diodes Df 2 and Df 4, as well as the filter inductors and capacitors L2, Cf 2, and Co2 are all included in the CONV2 sector of the schematic diagram. The self-commutated switches S2 and S4 as well as their antiparallel body diodes D2 and D4, as well as the free wheeling di The self-commutated switches (S5, S6, S7, and S8), as well as their corresponding body diodes (D5, S6, S7, and S8), that comprise the inverting stage are shown in Figure 1. The inversion step is shown in Figure 1. When the grid is linked to the inverter stage, Lg serves as an interface between the two, and this is referred to as a filter inductor in the industry (Lg). In this case, the capacitors are paired, and they represent the parasitic capacitance that occurs between the solar photovoltaic (PV) array and the ground potential. Take, for example, the image in Fig. 2. The buck mode is active when V_{pv1} is less than or equal to v_{co1} , and the buck mode is triggered when V_{pv2} is less than or equal to v_{co2} . The buck mode is activated when V_{pv2} is less than or equal to v_{co2} .

Activation of the buck mode is also possible when V_{pv2} is less than or equal to v_{co2} . MPP voltages are represented by the variables V_{pv1} and V_{pv2} , respectively, if PV1 and PV2 are utilised. When the output voltages of CONV1 and CONV2 are used, the MPP voltages are represented by the variables v_{co1} and v_{co2} , respectively. To achieve sinusoidal grid current (i_g) in buck mode operation, the duty ratios of S1 and S2 are changed sinusoidally, while those of S3 and S4 are maintained at zero during the operation. In the instance where V_{pv1} is more than or equal to V_{co1} , the CONV1 operates in boost mode; nevertheless, in the scenario where V_{pv2} is greater than or equal to V_{co2} , the CONV2 operates in boost mode as well. The duty ratios of the switches are increased in boost mode, and the duty ratios of the switches are changed in a sinusoidal manner to guarantee sinusoidal i_g is maintained. It is necessary to keep S1 and S2 turned on throughout the mode in order to achieve sinusoidal irradiation. It is critical to maintain synchronisation between the sinusoidal switching pulses produced by the switches of CONV1 and CONV2 and the grid voltage v_g in order to guarantee that the unity power factor is maintained while operating. For the positive half-cycle (PHC), the switches S5 and S8 must be kept turned on, while for the negative half-cycle (NHC), they must be kept turned off (NHC). In order to ensure that the negative half-cycle (NHC) is completed successfully, the switches S6 and S7 must remain on for the whole negative half-cycle (NHC), while the switches S5 and S8 must be switched off (NHC). As seen in Figure 3 (including standby mode), the proposed inverter is visible in all of its operating modes.

Results:

For the purpose of demonstrating the effectiveness of the proposed inverter, a PV array consisting of two PV subarrays is explored, with each subarray consisting of four series connected Canadian solar polycrystalline modules "CS6P-165PE" [25] is investigated [26]. Following are the MPP parameters for each subarray under standard test circumstances (STC), as shown in Table I. Simulation and testing were carried out with the help of parameters and elements.

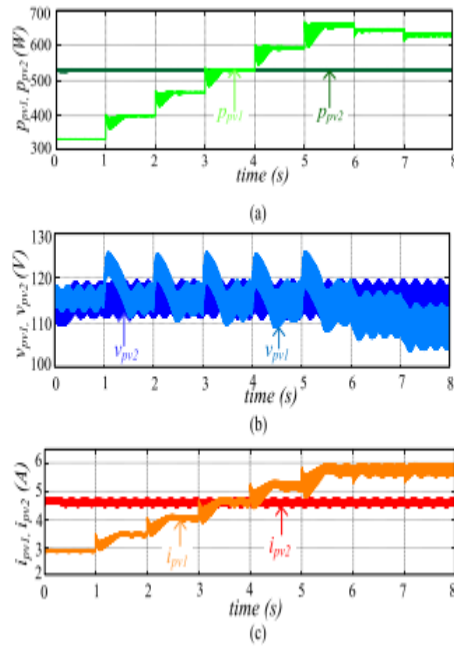

Fig5. 1. Simulated waveform. Variation in (a) $ppv1$ and $ppv2$, (b) v_{pv1} and v_{pv2} , and (c) $ipv1$ and $ipv2$ during entire range of operation.

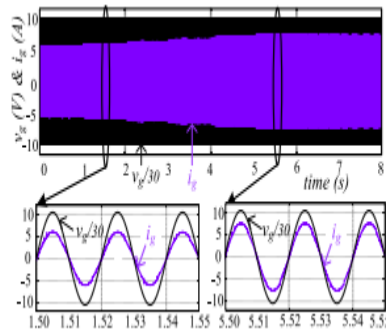

Fig5.2. Simulated waveform. v_g and i_g and their magnified views.

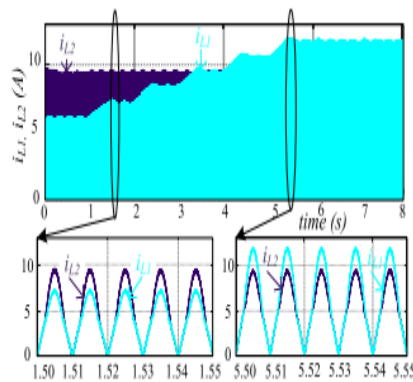

Fig5.3. Simulated waveform. i_{L1} and i_{L2} and their magnified views.

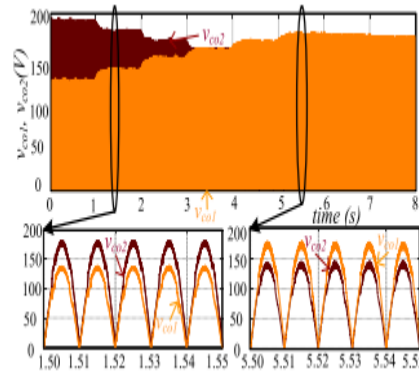

Fig5.4. Simulated waveform.vco1 and vco2 and their magnified views.

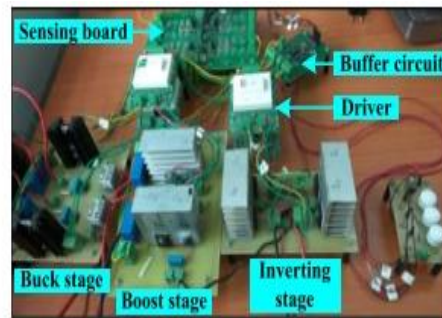

Fig5.5. Experimental prototype of the proposed inverter.

The magnified versions of i_g and v_g when (a) insolation of PV1 is 40% and insolation of PV2 is 80%, (b) insolation of PV1 is 100% and insolation of PV2 is 80%, the magnified versions of the PV1 and PV2 when (c) insolation of PV1 is 40% and insolation of PV2 is 80%, the magnified versions of the v_{pv1} and V_{pv2} when (d) insolation

CONCLUSION

To operate two subarrays at their maximum power points, this research proposes the development of a single-phase GCT buck and boost based PV inverter (MPPs). The following are just a few of the intriguing features of this inverter:

In a previous section, a feasible technique for minimising the effects of MECs on the PV array was presented.

Three things stood out: the high degree of operational efficiency (euro = 97.02 percent) and the substantial amount of money saved.

Component converters could be operated in a decoupled manner, which was useful.

4) A rudimentary MPPT algorithm was created to guarantee that the MPP functionality of the component converters was not damaged.

In addition, the PV arrays' leakage current kept within the German standard VDE 0126-11-1's limits. Analysis of the suggested inverter led to the creation of a model for the device's signals in a small form factor. The criteria and techniques for computing the output filter component values are discussed in this paper. To ensure the system's feasibility, extensive modelling studies were conducted, as well as extensive practical testing on a 1.5 kW inverter prototype that had been specifically built for this project. In the end, it was found that the technique was viable.

REFERENCES

[1] T. Shimizu, O. Hashimoto, and G. Kimura, "A novel high-performance utility-interactive photovoltaic inverter system," *IEEE Trans. Power Electron.*, vol. 18, no. 2, pp. 704–711, Mar. 2003.

- [2] S. V. Araujo, P. Zacharias, and R. Mallwitz, "Highly efficient single-phase transformerless inverters for grid-connected photovoltaic systems," *IEEE Trans. Ind. Electron.*, vol. 57, no. 9, pp. 3118–3128, Sep. 2010.
- [3] B. Ji, J. Wang, and J. Zhao, "High-efficiency single-phase transformerless PV H6 inverter with hybrid modulation method," *IEEE Trans. Ind. Electron.*, vol. 60, no. 5, pp. 2104–2115, May 2013.
- [4] R. Gonzalez, E. Gubia, J. Lopez, and L. Marroyo, "Transformerless single phase multilevel-based photovoltaic inverter," *IEEE Trans. Ind. Electron.*, vol. 55, no. 7, pp. 2694–2702, Jul. 2008.
- [5] H. Xiao and S. Xie, "Transformerless split-inductor neutral point clamped three-level PV grid-connected inverter," *IEEE Trans. Power Electron.*, vol. 27, no. 4, pp. 1799–1808, Apr. 2012.
- [6] A. Bidram, A. Davoudi, and R. S. Balog, "Control and circuit techniques to mitigate partial shading effects in photo voltaic arrays," *IEEE J. Photovolt.*, vol. 2, no. 4, pp. 532–546, Oct. 2012.
- [7] N. D. Kaushika and N. K. Gautam, "Energy yield simulations of interconnected solar PV arrays," *IEEE Trans. Energy Convers.*, vol. 18, no. 1, pp. 127–134, Mar. 2003.
- [8] H. Patel and V. Agarwal, "Maximum power point tracking scheme for PV systems operating under partially shaded conditions," *IEEE Trans. Ind. Electron.*, vol. 55, no. 4, pp. 1689–1698, Apr. 2008.
- [9] D. Nguyen and B. Lehman, "An adaptive solar photovoltaic array using model-based reconfiguration algorithm," *IEEE Trans. Ind. Electron.*, vol. 55, no. 7, pp. 2644–2654, Jul. 2008.
- [10] G. Velasco-Quesada, F. Guinjoan-Gispert, R. Pique-Lopez, M. RomanLumbreras, and A. Conesa-Roca, "Electrical PV array reconfiguration strategy for energy extraction improvement in grid-connected PV systems," *IEEE Trans. Ind. Electron.*, vol. 56, no. 11, pp. 4319–4331, Nov. 2009.